

SPLASH-PROOF MEGAPHONES

ER-1203
ER-1206
ER-1206S
ER-1206W

Water protection: IPX5

Thank you for purchasing TOA's Splash-Proof Megaphones.
Please carefully follow the instructions in this manual to ensure long, trouble-free use of your equipment.

1. SAFETY PRECAUTIONS

- Before installation or use, be sure to carefully read all the instructions in this section for correct and safe operation.
- Be sure to follow all the precautionary instructions in this section, which contain important warnings and/or cautions regarding safety.
- After reading, keep this manual handy for future reference.



CAUTION

Indicates a potentially hazardous situation which, if mishandled, could result in moderate or minor personal injury, and/or property damage.

- Cautions on Use
Be sure to observe the following instructions. Failing to observe may cause hearing impairment.
 - Reduce the volume to its lowest setting before use.
 - Never use the megaphone in close proximity to a person's ear.
 - Point the megaphone toward the ground when conducting operational tests.
- Make sure to observe the following handling precautions so that a fire or personal injury does not result from leakage or explosion of the battery.
 - Do not short, disassemble, heat nor put the battery into a fire.
 - Avoid using both new and old batteries together.
 - Never charge batteries of the type which are not rechargeable.
 - Do not solder a battery directly.
 - Be sure to use the specified type of batteries.
 - Note correct polarity (positive and negative orientation) when inserting a battery in the unit.
 - Avoid locations exposed to the direct sunlight, high temperature and high humidity when storing batteries.

2. GENERAL DESCRIPTION

The ER-1203 is a 3 W splash-proof megaphone and the ER-1206 series is a 6 W megaphone. Both feature IPX5 water-jet-resistant designs.

The ER-1206S offers a siren switch, and the ER-1206W is equipped with a whistle switch.

The use of the supplied battery spacer permits the ER-1206 series to be operated on four AA batteries instead of six batteries normally required.

Handle and mouthpiece with anti-bacteria treatment improve hygiene and safety during use.

3. HANDLING PRECAUTIONS

- The ER-1203/1206/1206S/1206W megaphones are waterproof to IPX5 standard that permits the use of megaphones in an environment where rain or water may be splashed. Never use them in water or in heavy rain, nor submerge them as doing so may cause unit failure.
- Immediately contact your TOA dealer if the following irregularities should occur. To avoid unit failure, make no further attempt to use the unit in these conditions.
 - Smoke coming from the unit or a strange smell detected.
 - Water or other foreign objects get inside the unit.
 - No sound heard (after checking to be sure that the batteries are loaded in correct orientation, and satisfactorily charged).
- Avoid storing the unit in humid or dusty locations, in locations exposed to direct sunlight, near heaters, or exposed to sooty smoke, as these conditions may result in unit failure.
- When batteries are left installed in the megaphone for extended periods of time, be sure to check them periodically for charge and leakage.
- Do not use the unit for extended periods of time with a distorted sound output. This could cause the inner parts to become hot and possibly result in unit failure.
- Noise may be produced when a mobile phone is used near the unit. However, this is not a failure. Use the mobile phone as far as possible from the unit.
- Use a tightly wrung-out damp cloth to clean the unit. If the unit becomes extremely dirty, use a cloth moistened in a neutral detergent and tightly wrung-out. Never use volatile liquids such as benzene or thinner to clean the unit, as these may deform or discolor its case.

4. NOMENCLATURE AND FUNCTIONS

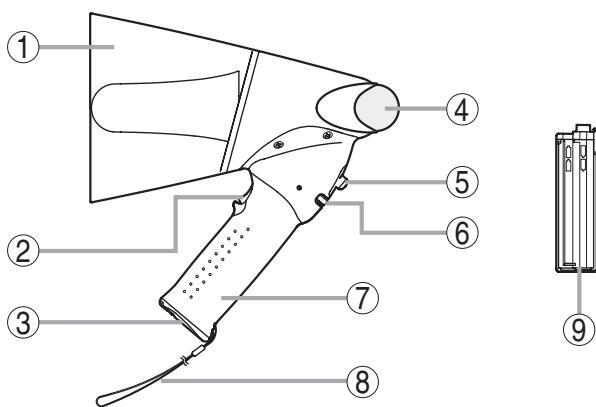

1. Speaker (outer horn)

2. Talk switch

Press to talk (power turns ON). Release to turn the power OFF.

3. Battery Cover

The battery compartment is built inside. Use care when opening and closing the battery cover.

4. Mouthpiece

Speak into the mouthpiece at a distance of about 1 cm. Anti-bacteria treated, the mouthpiece helps make such close contact during use hygienic and safe.

5. Signal tone switch (ER-1206S/W only)

[ER-1206S]

A siren tone sounds when this switch is pressed, and stops when pressed again.

[ER-1206W]

A whistle tone sounds while this switch is pressed, and stops when released.

Note: Output volume is fixed, and cannot be adjusted with the volume control.

6. Volume control

Rotate right to increase output volume.



Volume high

7. Handle

The handle with anti-bacteria treatment improve hygiene and safety during use.

8. Strap

Use this strap to carry the unit. (Length: approx. 60 cm)

9. Battery case

Houses AA batteries of 4 pieces for the ER-1203 or 6 pieces (4 pieces when the battery spacer is used) for the ER-1206 series.

Note: The battery spacer is installed in the handle (7) by the factory.

5. REPLACING THE BATTERIES

Note

If the megaphone is at all wet, be sure to dry it thoroughly before opening the battery cover to replace the batteries.

- Step 1.** Open the battery cover to remove the battery case from the handle.
To release the battery cover lock, press the lock tab in the direction indicated by the arrow.

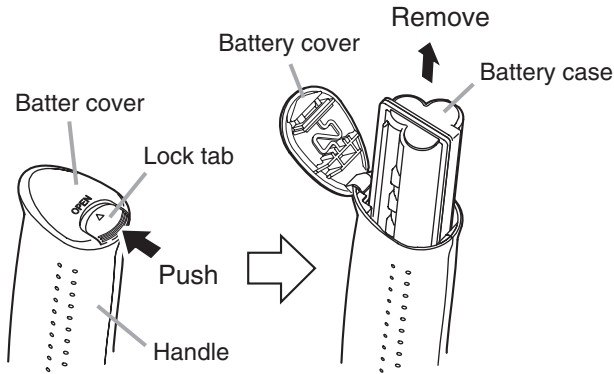

- Step 2.** Insert six AA batteries referring to the polarity diagram on the inside of the battery compartment.
Four batteries are required for the ER-1203, and six batteries for the ER-1206 series.
Unlock the battery case's lock knob to open the cover.
Insert the batteries into the case, carefully noting the battery polarity indications.

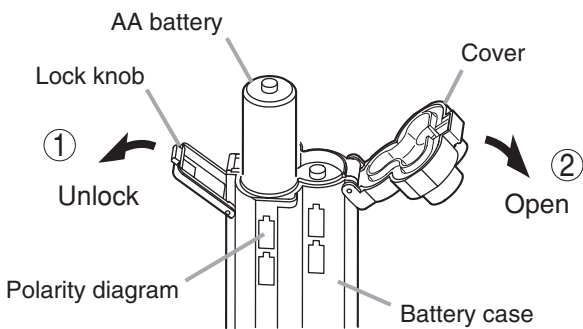

- Step 3.** After confirming the correct battery polarity, close the battery case cover.
Ensure that the cover is securely locked in place with the lock knob.

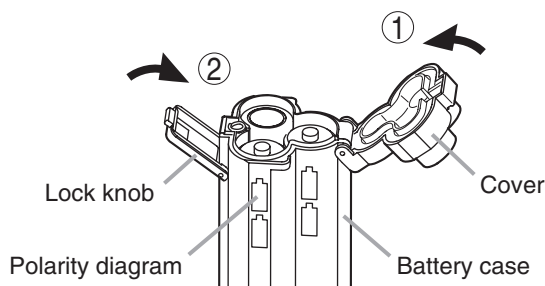

- Step 4.** Replace the battery case in the handle and close the battery cover.
Take care about the correct orientation of the battery case.
To close the battery cover, push the battery cover and slide the lock tab in the direction of the arrow.

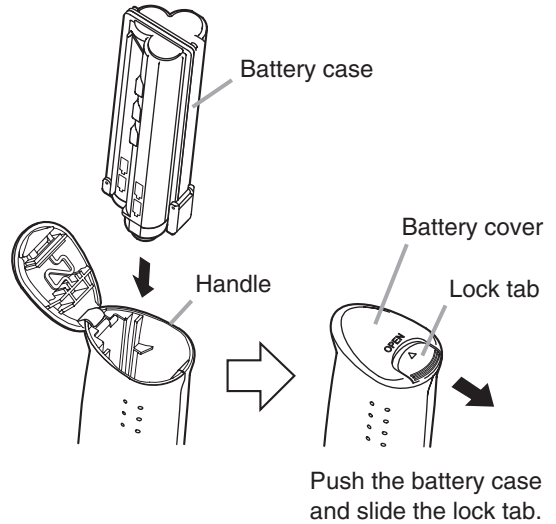

5.1. Using the battery spacer (ER-1206 series only)

The ER-1206 series can operate on four AA batteries instead of 6 batteries with the additional use of the supplied battery spacer.
Insert the battery spacer into any of three battery chambers inside the case, then insert the four batteries into the remaining two chambers according to the battery polarity diagram attached to the case.

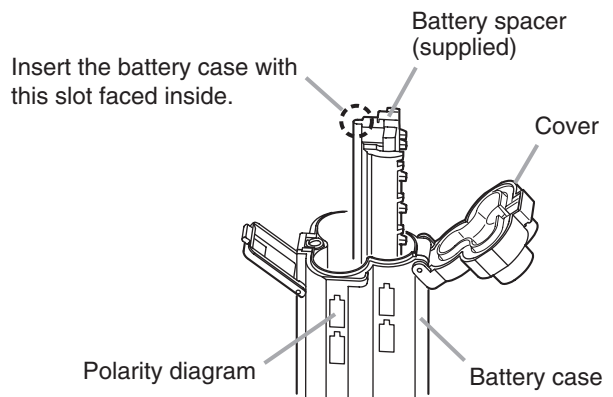

Note: Battery life when operated on 4 batteries is shorter than when operated on 6 batteries. The volume when operated on 4 batteries is also lower than when operated on 6 batteries. Therefore, adjust the volume to an appropriate output with the volume control.

6. MEGAPHONE WALL MOUNTING BRACKET

Using the optional SP-1100 Wall Mounting Bracket permits the megaphone to be mounted on a wall.

Not only can the megaphone be mounted so that its location is seen at a glance, but it can also be attached and detached easily.

Note

For the procedures of installation and use, refer to the instruction manual enclosed with the SP-1100 bracket.

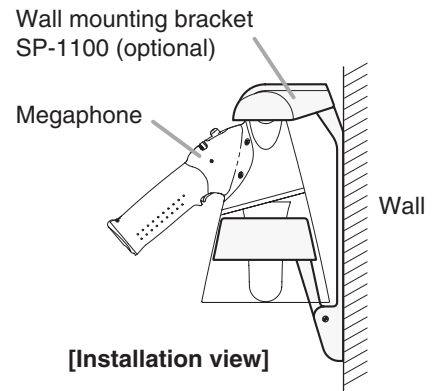

7. HOW TO USE

⚠ CAUTION

- Before pressing the talk switch, fully turn down the volume.
- Point the megaphone toward the ground when conducting operational tests.

Step 1. Using the volume control, adjust the volume to an appropriate level that does not generate feedback when holding down the talk switch.

Howling is more likely to occur when using the megaphone indoors and other spaces with significant echo. Particularly when the batteries are new, it may be impossible to adjust the volume to maximum without causing howling. In such cases, set the volume to about mid-level.

Step 2. Speak into the mouthpiece at a distance of about 1 cm.

Notes

- Speaking too far from the mouthpiece or in too soft voice may result in insufficient volume.
- Moisture droplets collecting in the hole on the mouthpiece may cause noticeably insufficient volume. Wipe the droplets away with a cloth or other material and allow the area to dry sufficiently before resuming use.

8. SPECIFICATIONS

Model No.	ER-1203	ER-1206	ER-1206S	ER-1206W	
Output	Rated 3 W, Max. 4 W	Rated 6 W, Max. 10 W			
Power Source	AA (R6P) battery x 4 (6 V DC)	AA (R6P) battery x 6 (9 V DC) or AA (R6P) battery x 4*1 (6 V DC)			
Signal	—	—	Siren	Whistle	
Battery Life*2 (approx.)	Voice: 8 hours	[With use of AA (R6P) battery x 6]			
		Voice: 8 hours	Voice: 8 hours, Signal: 20 minutes		
		[With use of AA (R6P) battery x 4]			
		Voice: 5 hours	Voice: 5 hours, Signal: 10 minutes		
Audible Range*3 (approx.)	Voice: 125 m	Voice: 250 m	Voice: 250 m, Signal: 315 m		
Magnetic Circuit	Neodymium magnet, inner magnet type				
Diaphragm	Polyimide film (voice coil, bobbin)				
Anti-bacteria Treatment	Mouth and handle				
Water protection	IPX5				
Operating Temperature	-10 to +40°C				
Finish	Horn	ASA resin, clear dark gray	ASA resin, clear dark gray	ASA resin, clear red	ASA resin, clear dark gray
	Others	ASA resin, dark gray	ASA resin, dark gray	ASA resin, red	ASA resin, yellow
Dimensions	137 (w) x 257.8 (h) x 210 (d) mm		154 (w) x 266 (h) x 250 (d) mm		
Weight (without batteries)	610 g		660 g	680 g	

*1 With use of the supplied battery spacer

*2 Battery life estimates assume 30 minutes of continuous use per day.

*3 Audible range estimates assume use on a relatively quiet street using new batteries and will vary depending on remaining battery capacity, surrounding noise, wind direction, obstacles and other environmental conditions.

Notes

- No accessory batteries are supplied.
- The design and specifications are subject to change without notice for improvement.

• Accessory

Battery spacer
(ER-1206 series only) 1

• Optional products

Wall mounting bracket: SP-1100